

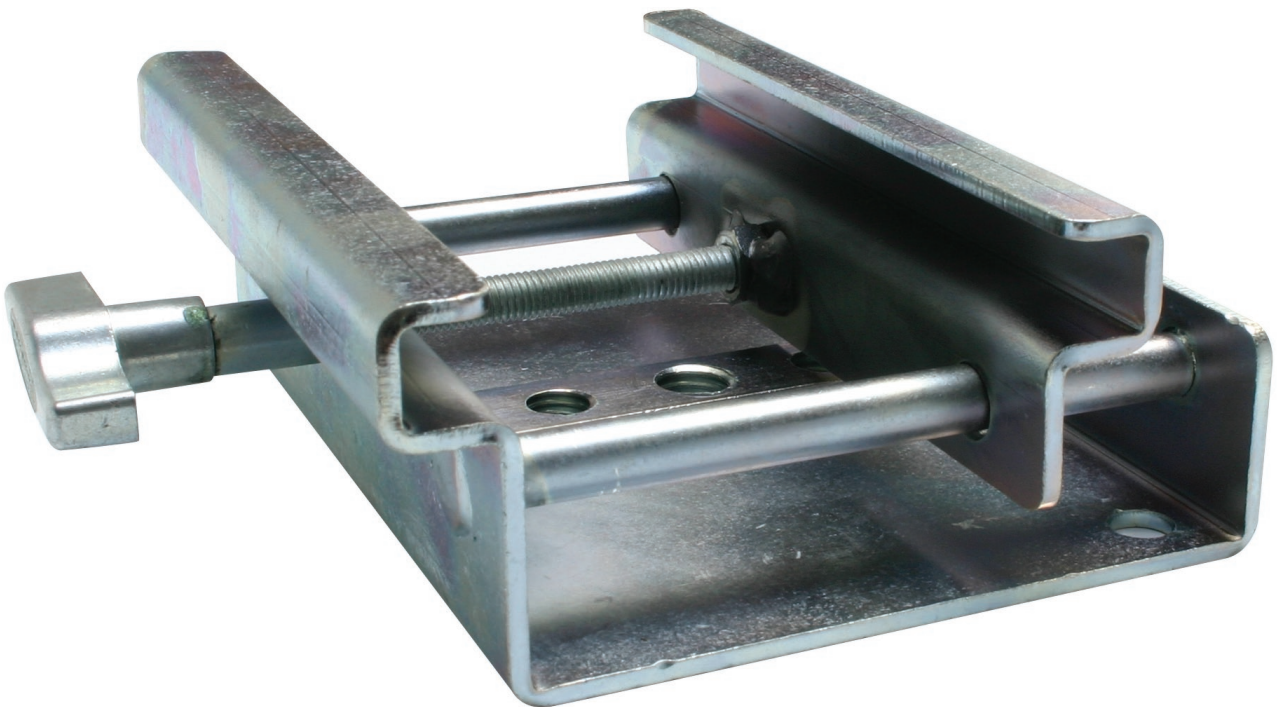

User Manual

www.doughty-engineering.co.uk

T28870 Marquee Clamp



Version 08/11



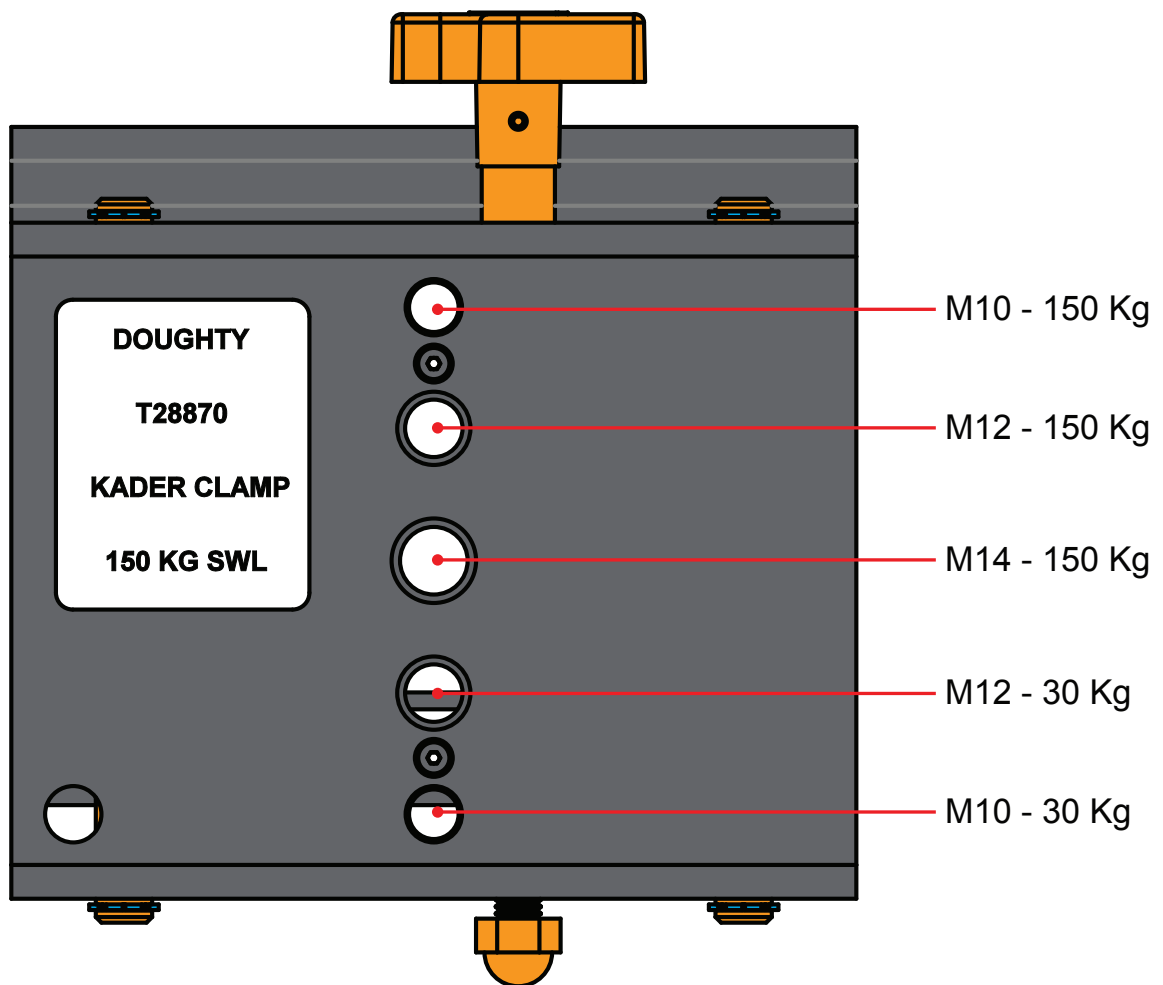
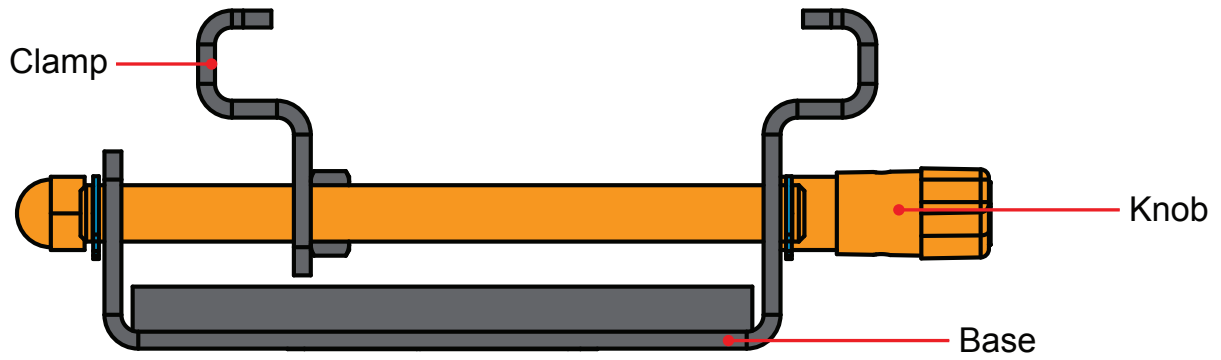

www.doughty-engineering.co.uk

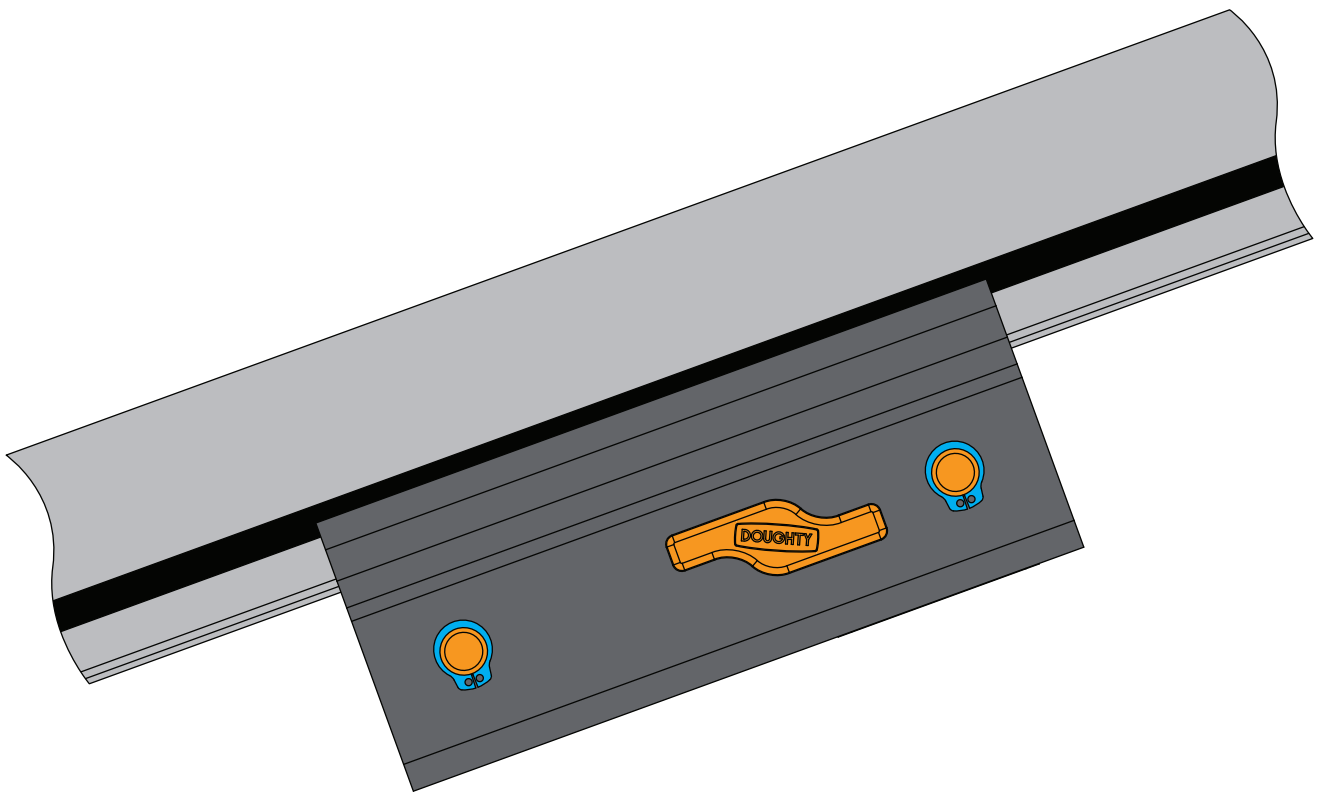

1. Never exceed the Safe Working Load (SWL) shown on the clamp. (See previous page)
2. Only use the clamp within its designed parameters. (Clear Span Marquee Profile)
3. All clamps should be visually inspected before use. In the event of any damage the clamp should be taken out of service and returned to an 'Approved Doughty Service Agent' for inspection. (see our dealer locator on our web site for a comprehensive list of Authorised Service Agents)
4. When used in conjunction with other accessories, care must be taken to ensure that the minimum SWL of any component is not exceeded.



 DOUGHTY ENGINEERING LTD	DATA SHEET	TITLE: MARQUEE CLAMP	PART NOS: T28870 - SILVER	MATERIAL : STEEL	WEIGHT: 1.30 KG	SWL: SEE DWG	FINISH: ZINC PLATED	NOTES:	<p style="text-align: center;">STRICTLY FOR REFERENCE PURPOSES ONLY</p>	 THIRD ANGLE PROJECTION
--	-------------------	----------------------	------------------------------	---------------------	--------------------	-----------------	------------------------	--------	--	---

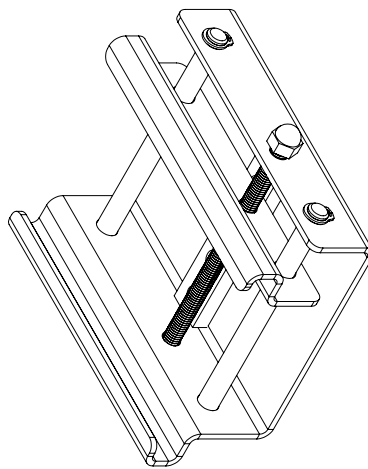
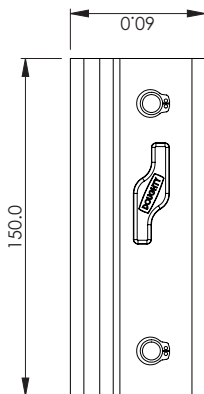
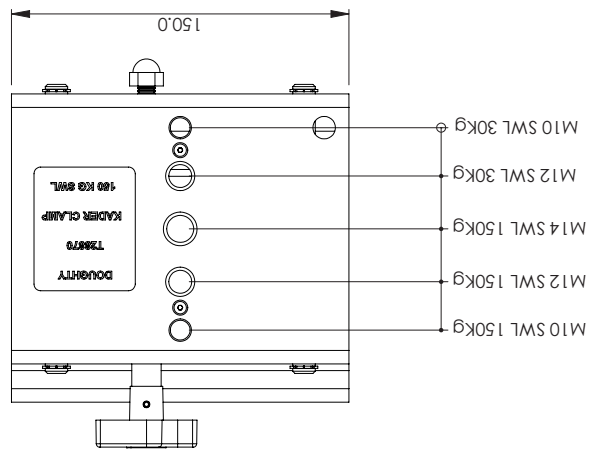
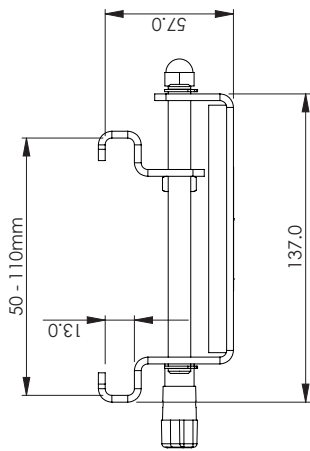



Doughty Engineering Limited

CROW ARCH LANE, RINGWOOD, HANTS, BH24 1NZ. ENGLAND

Telephone: +44 (0) 1425 478961 Fax: +44 (0) 1425 474481

www.doughty-engineering.co.uk

email:sales@doughty-engineering.co.uk

EC DECLARATION OF CONFORMITY

Doughty Engineering Limited hereby certify that the equipment stated below has been designed to comply with all relevant sections of the specifications referenced below and complies with all the applicable Essential Requirements of the EC Directives and amendments and the National Laws and Regulations adopting these Directives.

Description: Marquee Clamp

Model/s: Part No. T28870

SWL: 30 Kg - 150 Kg **Factor:** 5:1

are in conformity with the provision of the following EC Directives:

MACHINERY DIRECTIVE 98/37/EC

Harmonised Standards applied:

EN 292-1-2:1991

BS EN ISO 9001:1994

National Technical Standards & Specifications applied:

BS 7905-1:2001

Signed:

A handwritten signature in black ink, appearing to read "S. Wright".

Date:11-08-11

Name: Stephen Wright

Position: Director

Being the responsible person appointed by the manufacturer.



DEQ 083 Rev 4

Company Registration No. London 972614
Registered Office: Crow Arch Lane, Ringwood, Hants, BH24 1NZ
Directors: M.B.Lister. J.C.G. Chiverton. N.D. Curtis. S.C. Wright





Doughty Engineering Ltd

Crow Arch Lane

Ringwood, Hampshire, BH24 1NZ

Tel: +44 (0) 1425 478961 Fax: +44 (0) 1425 474481

email: sales@doughty-engineering.co.uk

Web: www.doughty-engineering.co.uk

Note: Whilst every effort has been made to ensure that the information contained within this manual is correct, Doughty Engineering does not accept any liability for errors or omissions. Specifications and technical data are intended for guidance purposes only and may vary.